



2RB

額定電壓	DC24 / AC110 / AC220	Rated voltage	DC24 / AC110 / AC220
額定轉速	2500 r\min	Rated R.P.M	2500 r\min
額定輸出	30 W	Rated output power	30 W
齒輪箱搭配	IG-60S / 2GB	Gear head match	IG-60S / 2GB
重量	800g	Weight	800g
轉向	CW / CCW	Direction	CW / CCW
噪音	50cm – 50db	Noise	50cm – 50db
使用溫度/濕度	-15C~60C / RH85%↓	Using temp. / humidity	-15C~60C / RH85%↓
防護等級	IP545	Grade of protection	IP545
絕緣等級	E	Insulation class	E
絕緣抗壓	500V/3mA – 60sec	Voltage resistance	500V/3mA – 60sec
絕緣阻抗	10MΩ>	Insulation resistance	10MΩ>

無刷馬達 Brushless Motor

規格表 Specification

		DC24V	AC110V	AC220V
驅動器搭配	Driver system match	DBM24V	DBC110V	DBC220V
齒輪箱搭配	Gear head match		1G60 / 2GB	
額定轉速	Rated R.P.M	r/min	2500	
最高轉速	Max speed	r/min	3000	
額定輸出	Rated out put	W	30	
額定轉矩	Rated torque	N/m (kgf-cm)	0.12 (1.2)	
起動轉矩	Start torque	N/m (kgf-cm)	0.15 (1.5)	
速度控制範圍	Speed control range	r/min	15 ~ 3000	
輸入電源 In put				
電壓	Voltage	V	DC24±10%	AC110±15% AC220±15%
額定電流	Rated current	A	1.8	1 0.5
最大輸入電流	Max unput current	A	2.1	1.5 1
轉速變動率 Rating of R.P.M fluctuation				
負載	Loading	T	±0.5%	
電壓	Voltage	A	0.2~4% ± 10%	
溫度	Temperature	°C	0~3% (0~50°C)	

尺寸圖 Appearance size

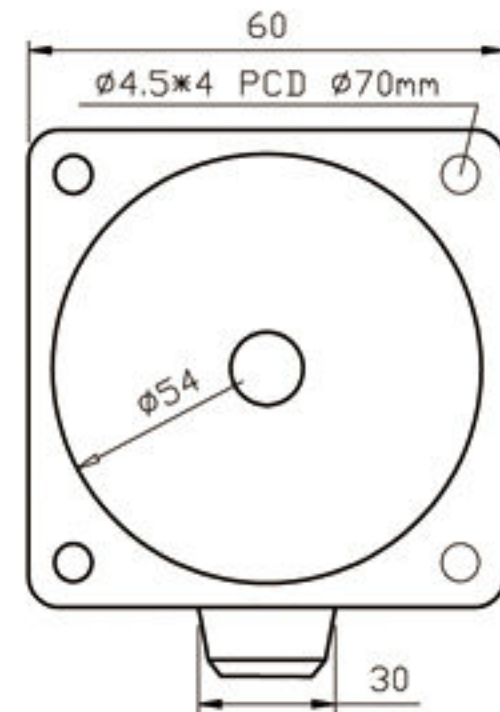
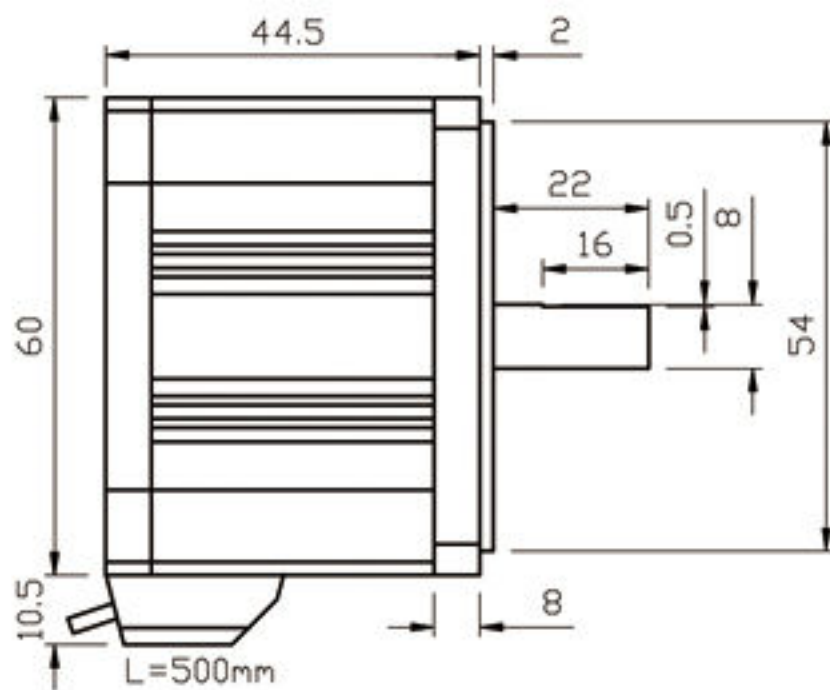

動力測試圖 R.P.M performace curve

